

Flat Pak I/O Modules

Features

- Industry-standard plug-in modules
- 4000 VAC optical isolation
- Input modules handle both AC and DC inputs
- AC output module has zero voltage turn-on, zero current turn-off
- UL and CSA recognized; RoHS lead-free; CE low voltage and EMC

Description

Flat Pak I/O modules include AC and DC input and output modules. All are industry-standard, plug-in modules with 4000 volts of optical isolation between the field side and the logic side, and all are recognized by UL and CSA.

Because of their low profile, Flat Pak modules are ideal for user-designed printed circuit boards where the standard single-channel or Quad Pak modules do not provide an exact fit.

AC/DC Input Modules

Flat Pak input modules handle either alternating current (AC) or direct current (DC). These modules are used for sensing ON/OFF voltage levels. All Flat Pak input modules are designed with filtering on the input and a hysteresis amplifier for high noise rejection and transient free “clean” switching. Each module provides up to 4000 V of optical isolation between field inputs and the logic side of the circuit.

Typical uses and applications include sensing the presence or absence of voltage from sources such as:

- Proximity switches
- Limit switches
- Selector switches
- Push-button and toggle switches
- Thermostats
- Photoelectric switches
- TTL-compatible devices



Flat Pak I/O Modules

AC Output Module

The OAC5P Flat Pak output module is used for controlling or switching AC loads. It is equivalent to a single-pole, single-throw, normally open contact (FORM A, SPST-NO, Make). The OAC5P features zero voltage turn-on and zero current turn-off.

Typical uses and applications for the OAC5P include switching the following loads:

- Relays
- Solenoids and contactors
- Motor starters
- Heaters
- Lamps or indicators

DC Output Module

The ODC5P Flat Pak output module is used for controlling or switching DC loads. Typical uses and applications for the ODC5P include switching the following loads:

- DC relays
- DC solenoids
- DC motor starters
- DC lamps or indicators

Part Numbers

Part	Description
IAC5P	Flat Pak input module, 90–140 VAC/VDC
IDC5P	Flat Pak input module, 10–32 VDC or 12–32 VAC
OAC5P	Flat Pak output module, 12–140 VAC
ODC5P	Flat Pak output module, 5–60 VDC

Specifications—AC/DC Input Modules

	IAC5P	IDC5P
Input Voltage Range	90–140 VAC or VDC	10–32 VDC or 12–32 VAC
Input Current at Maximum Line	11 mA	25 mA
Turn-on Time	20 ms	5 ms
Turn-off Time	20 ms	5 ms
Input Allowed for No Output	3 mA, 45 V	1 mA, 3 V
Logic Supply Voltage, Nominal	5 VDC	5 VDC
Logic Supply Voltage Range	4.5–6.0 VDC	4.5–6.0 VDC
Logic Supply Current at Nominal Logic Voltage	12 mA	12 mA
Input Resistance (R1 in Schematic Diagram)	14,000 Ohms	1500 Ohms
Control Resistance (Rc in Schematic Diagram)	220 Ohms	220 Ohms
Optical Isolation, Input-to-output	4000 Vrms	4000 Vrms
Output Voltage Drop	0.4 V @ 50 mA	0.4 V @ 50 mA
Output Current	50 mA	50 mA
Output Leakage with No Input	100 μ A maximum @ 30 VDC	100 μ A maximum @ 30 VDC
Operating Temperature	–30 to 70 °C	–30 to 70 °C
Agency Approvals	UL (E58169), CSA (35852), RoHS, CE	UL (E58169), CSA (35852), RoHS, CE
Warranty	Lifetime	Lifetime

Flat Pak I/O Modules

Specifications—AC and DC Output Modules

	OAC5P	ODC5P
Operating Voltage Range	12–140 VAC	5–60 VDC
Line Voltage, Nominal	120 VAC	n/a
Current Rating	3 A @ 45 °C ambient 2 A @ 70 °C ambient	3 A @ 45 °C ambient 2 A @ 70 °C ambient
Off-state Leakage at Maximum Voltage	5 mA, rms	1 mA
Logic Voltage, Nominal	5 VDC	5 VDC
Logic Voltage Range (Vcc)	2.5–8 VDC	2.5–8 VDC
Logic Pickup Voltage	2.55 VDC	2.5 VDC
Logic Dropout Voltage	1 VDC	1 VDC
Logic Input Current at Normal Logic Voltage (I _{out} in Schematic Diagram)	12 mA	12 mA
Control Resistance (R _c in Schematic Diagram)	220 Ohms	220 Ohms
One-second Surge	n/a	5 A
One-cycle Surge	80 A peak	n/a
Peak Repetitive Voltage	500 V	n/a
Minimum Load Current	20 mA	n/a
Operating Frequency	25–65 Hz	n/a
Turn-on Time	1/2 cycle maximum, zero voltage	100 microseconds
Turn-off Time	1/2 cycle maximum, zero current	750 microseconds
DV/DT, Off-state	200 V/microsecond	n/a
DV/DT, Commutating	Snubbed for rated 0.5 power factor load	n/a
Output Voltage Drop Maximum Peak	1.6 V	1.6 V
Operating Temperature	–30 to 70 °C	–30 to 70 °C
Agency Approvals	UL (E58169), CSA (35852)	UL (E58169), CSA (35852)
Warranty	Lifetime	Lifetime

Schematic—Input Modules

AC/DC Inputs (IAC5P and IDC5P)

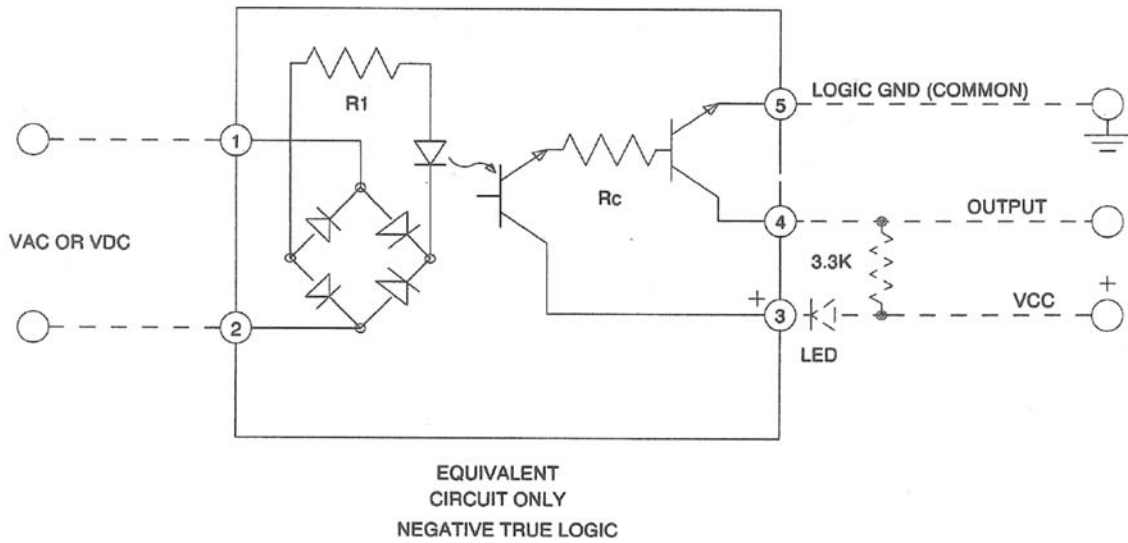

Flat Pak I/O Modules

Schematics—Output Modules

AC Output (OAC5P)

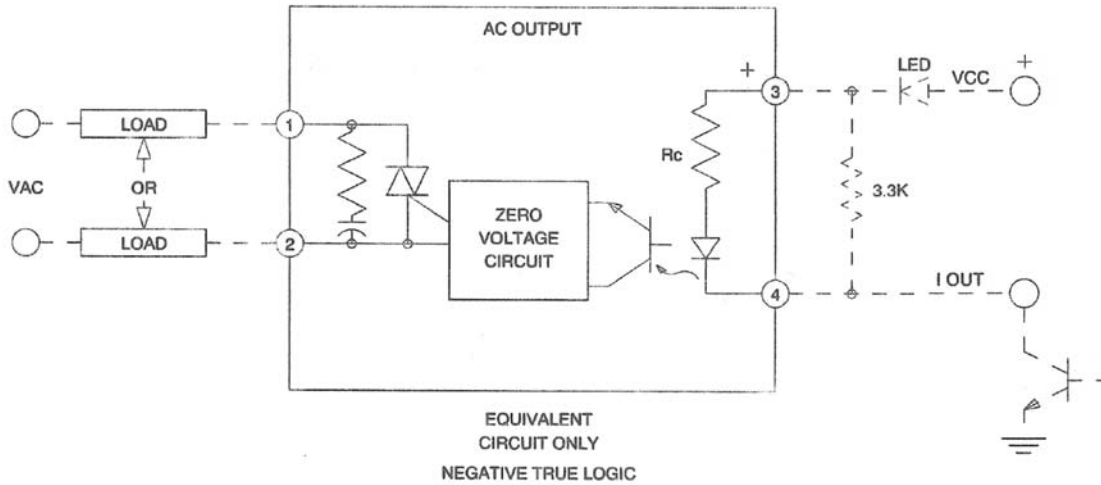

DC Output (ODC5P)

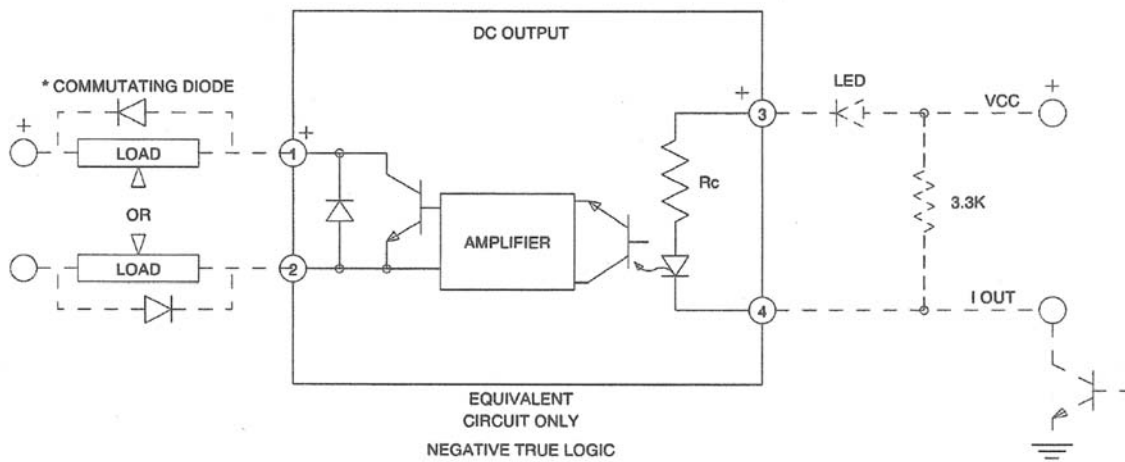

* Must be used on inductive loads.

Note: Also compatible with Totem Pole or 3-State Output.

Dimensional Drawing—All Flat Pak Modules

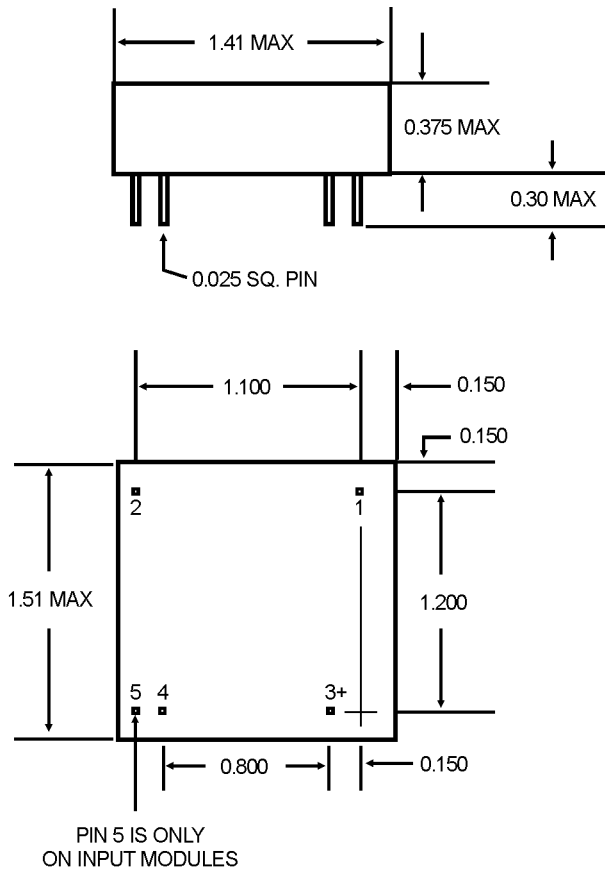

More About Opto 22

Products

Opto 22 develops and manufactures reliable, flexible, easy-to-use hardware and software products for industrial automation, energy management, remote monitoring, and data acquisition applications.

OptoEMU Energy Management System

The easy-to-use OptoEMU Sensor monitors electrical energy use in your facility and delivers detailed, real-time data you can see and analyze. The Sensor can monitor energy data from pulsing meters, electrical panels or subpanels, and equipment. View energy data online using a software service or incorporate the data into your control system for complete energy management.

SNAP PAC System

Designed to simplify the typically complex process of selecting and applying an automation system, the SNAP PAC System consists of four integrated components:

- SNAP PAC controllers
- PAC Project™ Software Suite
- SNAP PAC brains
- SNAP I/O™

SNAP PAC Controllers

Programmable automation controllers (PACs) are multifunctional, modular controllers based on open standards.

Opto 22 has been manufacturing PACs for over two decades. The standalone SNAP PAC S-series and the rack-mounted SNAP PAC R-series both handle a wide range of digital, analog, and serial functions for data collection, remote monitoring, process control, and discrete and hybrid manufacturing.

SNAP PACs are based on open Ethernet and Internet Protocol (IP) standards, so you can build or extend a system easily, without the expense and limitations of proprietary networks and protocols.

PAC Project Software Suite

Opto 22's PAC Project Software Suite provides full-featured, cost-effective control programming, HMI (human machine interface) development and runtime, OPC server, and database connectivity software for your SNAP PAC System.

Control programming includes both easy-to-learn flowcharts and optional scripting. Commands are in plain English; variables and I/O point names are fully descriptive.

PAC Project Basic offers control and HMI tools and is free for download on our website, PAC Project Professional, available for separate purchase, adds

OptoOPCServer, OptoDataLink, options for controller redundancy or segmented networking, and support for legacy Opto 22 serial *mistic*™ I/O units.

SNAP PAC Brains

While SNAP PAC controllers provide central control and data distribution, SNAP PAC brains provide distributed intelligence for I/O processing and communications. Brains offer analog, digital, and serial functions, including thermocouple linearization; PID loop control; and optional high-speed digital counting (up to 20 kHz), quadrature counting, TPO, and pulse generation and measurement.

SNAP I/O

I/O provides the local connection to sensors and equipment. Opto 22 SNAP I/O offers 1 to 32 points of reliable I/O per module, depending on the type of module and your needs.

Analog, digital, and serial modules are all mixed on the same mounting rack and controlled by the same processor (SNAP PAC brain or rack-mounted controller).

Quality

Founded in 1974, Opto 22 has established a worldwide reputation for high-quality products. All are made in the U.S.A. at our manufacturing facility in Temecula, California. Because we do no statistical testing and each part is tested twice before leaving our factory, we can guarantee most solid-state relays and optically isolated I/O modules for life.

comprehensive technical support for Opto 22 products. Our staff of support engineers represents decades of training and experience. Support is

Additional support is always available on our website: how-to videos, OptoKnowledgeBase, self-training guide, troubleshooting and user's guides, and OptoForums.

In addition, hands-on training is available for free at our

contact Opto 22 headquarters at
or 951-695-3000, or visit our website at

